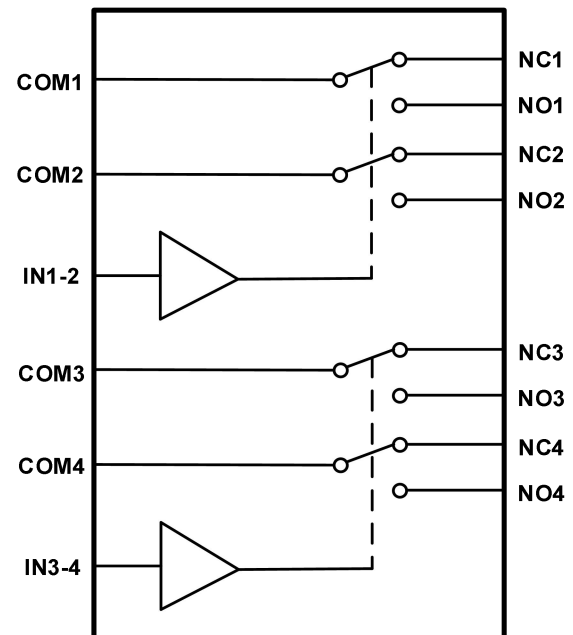

GT4899

High Speed, Low Voltage Dual DPDT Analog Switch

1 Features	2 Application
<ul style="list-style-type: none"> - Operate from 1.65 V to 5.5 V - High bandwidth: 350 MHz - Low on-state resistance: 3.5 Ω @ 4.5 V(typ) - Break-before-make switching - Rail-to-Rail operation - TTL/CMOS compatible - Operation temperature range: -40°C to +85°C 	<ul style="list-style-type: none"> - Communication systems - Portable instrumentation - Video switching - Battery-Operated equipment - Cell phones

3 Description	Circuit Diagram
<p>The GT4899 is a high-speed, low-voltage, dual-independent double-pole double-throw (DPDT) COMS analog switch that is designed to operate from a single +1.65V to +5.5V power supply. It features high-bandwidth (350 MHz) and low on-resistance (3.5 Ω @ 4.5 V).</p> <p>The GT4899 is configured as a DPDT device with two logic control inputs that control two multiplexer/demultiplexer each. The configuration can also be used as a dual differential 2-to-1 multiplexer/demultiplexer.</p> <p>GT4899 is available in QFN-3×3-16L and UTQFN1.8×2.6-16L.</p>	

4 Revision History

Revision	Date	Note
Rev. A0. 1	2024. 06. 27	Original Version
Rev. A0. 2	2024. 08. 12	Updated New Package
Rev. A1. 0	2024. 08. 30	Official Version

The latest datasheet version should be checked on the GTIC official website, as the company does not actively inform customers about updates to the datasheet.

5 Device Summary, Pin and Packages

Table 5-1. Device Summary⁽¹⁾

Serial Name	Part Name	Package	Body Size (Nom)	Marking ⁽²⁾⁽⁴⁾	MSL ⁽³⁾	Package Qty
GT4899	GT4899QE	QFN3×3-16L	3.00mm×3.00mm×0.75mm	GT4899 XXXXX	3	Tape and Reel,3000
GT4899	GT4899UE	UTQFN1.8×2.6- 16L	1.80mm×2.60mm×0.55mm	GT4899 XXXXX	3	Tape and Reel,3000

(1) For all available packages, please contact product sales.

(2) There may be additional marking, which relates to the lot trace code information (data code and vendor code), the logo or the environmental category on the device.

(3) MSL, The Moisture Sensitivity Level rating according to the JEDEC industry standard classifications.

(4) "XXXXX" in Marking will be appeared as the batch code.

5 Device Summary, Pin and Packages(Continued)

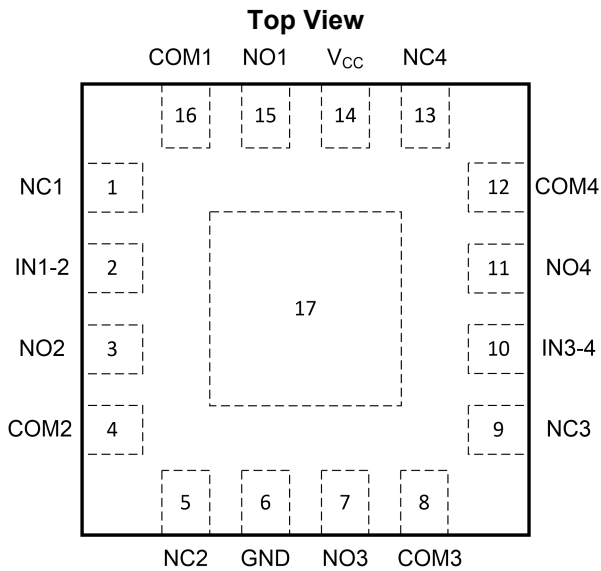
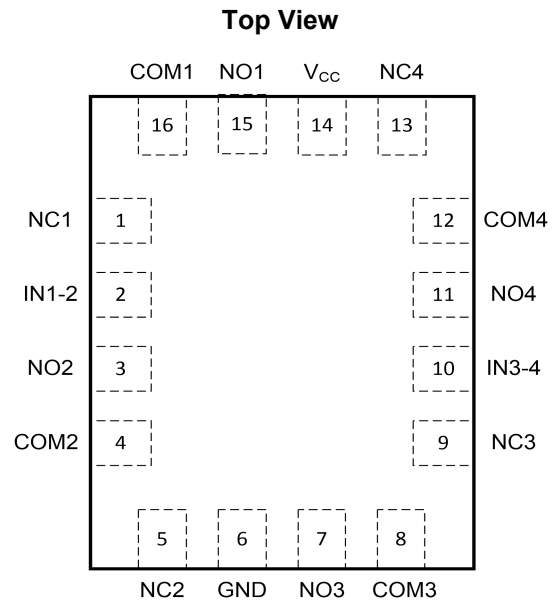
Fig.5-1. GT4899: QE (QFN3x3-16L) Package

Fig.5-2. GT4899: UE (UTQFN1.8x2.6-16L) Package
Table 5-2 Pin definition

Pin		Description
Name	QE UE	
NC1	1	Normal closed terminal switch 1
IN1-2	2	Select input,control switch 1 and switch 2
NO2	3	Normal open terminal switch 2
COM2	4	Common terminal switch 2
NC2	5	Normal closed terminal switch 2
GND	6	Ground
NO3	7	Normal open terminal switch 3
COM3	8	Common terminal switch 3
NC3	9	Normal closed terminal switch 3
IN3-4	10	Select input,control switch 3 and switch 4
NO4	11	Normal open terminal switch 4
COM4	12	Common terminal switch 4
NC4	13	Normal closed terminal switch 4
V _{CC}	14	Supply Voltage
NO1	15	Normal open terminal switch 1
COM1	16	Common terminal switch 1

Table 5-3 Function Table

IN1-2	Switch state
0	NC1=COM1,NC2=COM2
1	NO1=COM1,NO2=COM2
IN3-4	Switch state
0	NC3=COM3,NC4=COM4
1	NO3=COM3,NO4=COM4

6 Voltage, Temperature, ESD and Thermal Ratings

6.1 Absolute Maximum Ratings⁽¹⁾

Parameters		Min.	Max.	Unit
V _{CC}	Supply voltage range	-0.3	6.0	V
V _{IN}	Input voltage range	-0.3	6.0	V
	Analog, Digital voltage Range ⁽²⁾	-0.3	V _{CC} +0.3	V
	Continuous Current NO, NC or COM	-100	+100	mA
I _{PEAK}	Continuous Channel current	-160	+160	mA
T _J	Junction temperature	-65	150	°C
T _{stg}	Storage temperature	-65	150	°C

(1) Stresses beyond those listed under "Absolute Maximum Ratings" may cause permanent damage to the device. These are stress ratings only, and functional operation of the device at these or any other conditions beyond those indicated under "Recommended Operating Conditions" is not implied. Exposure to absolute-maximum-rated conditions for extended periods may affect device reliability.

(2) The input and output negative-voltage ratings may be exceeded if the input and output current ratings are observed.

6.2 ESD Ratings

ESD		Value	Unit	
V(ESD)	Electrostatic discharge	Human-Body Model (HBM) ⁽¹⁾	3.5 K	V
		Charged-Device Model (CDM) ⁽²⁾	2 K	V

(1) JEDEC document JEP155 states that 500-V HBM allows safe manufacturing with a standard ESD control process.

(2) JEDEC document JEP157 states that 250-V CDM allows safe manufacturing with a standard ESD control process.

6.3 Recommended Operating Conditions⁽¹⁾

Over operating free-air temperature range (unless otherwise noted)

Symbol	Parameter		Min	Max	Units
V _{CC}	Supply voltage	Operating	1.65	5.5	V
V _{CTRL}	Control Input voltage	Operating	0	V _{CC}	V
V _{SW}	Switch I/O voltage	Operating	0	V _{CC}	V
T _A	Ambient temperature		-40	85	°C

(1) All unused digital inputs of the device must be held at V_{CC} or GND to ensure proper device operation

7 Electrical Specifications

7.1 DC Electrical Characteristics

$V_{CC}=1.65V$ to $5.5V$, FULL= $-40^{\circ}C$ to $+125^{\circ}C$. Typical values are at $T_A=+25^{\circ}C$ (unless otherwise noted)

Parameter	Symbol	Conditions	V_{CC}	Temp	Min	Typ	Max	Units
Analog Signal Range	V_{NO}, V_{NC}, V_{COM}				0		V_{CC}	V
On-Resistance	R_{ON}	V_{NO} or $V_{NC}=V_{CC}/2$, $I_{COM}=-100mA$	4.5V	$+25^{\circ}C$		3.5	6	Ω
			3V	$+25^{\circ}C$		7	10	
			2.3V	$+25^{\circ}C$		12	22	
			1.65V	$+25^{\circ}C$		15	27	
On-Resistance Match Between Channels	ΔR_{ON}	V_{NO} or $V_{NC}=V_{CC}/2$, $I_{COM}=-100mA$	4.5V	$+25^{\circ}C$		0.3	1	Ω
			3V	$+25^{\circ}C$		1	3	
On-Resistance Flatness	RFLAT (ON)	$0 \leq V_{NO}$ or $V_{NC} \leq V_{CC}$, $I_{COM}=-100mA$	4.5V	$+25^{\circ}C$		1	1.5	Ω
			3V	$+25^{\circ}C$		3.5	5.5	
			2.3V	$+25^{\circ}C$		9	14	
			1.65V	$+25^{\circ}C$		12	18	
NC,NO Off Leakage Current	$I_{NC(OFF)}, I_{NO(OFF)}$	V_{NO} or $V_{NC}=1V, 4.5V, V_{COM}=4.5V, 1V$	5.5 V	Full			1	μA
NC,NO,COM On Leakage Current	$I_{NC(ON)}, I_{NO(ON)}, I_{COM(ON)}$	$V_{COM}=1V, 4.5V, V_{NO}$ or $V_{NC}=1V, 4.5V$, or floating	5.5 V	Full			1	μA
Input High Voltage	V_{INH}		4.5V	Full	1.8			V
			3V	Full	1.5			V
Input Low Voltage	V_{INL}		4.5V	Full			0.5	V
			3V	Full			0.4	V
Input Leakage Current	I_{IN}	$V_S=V_{CC}$ or 0	5.5 V	Full			1	μA
Power Supply Current	I_{CC}	$V_S=GND$ or V_{CC}	5.5 V	Full			1	μA

7 Electrical Specifications(Continued)

7.2 Switch And AC Characteristics

$V_{CC}=1.65V$ to $5.5V$, FULL= $-40^{\circ}C$ to $+125^{\circ}C$. Typical values are at $T_A=+25^{\circ}C$ (unless otherwise noted)

Parameter	Symbol	Conditions	V_{CC}	Temp	Min	Typ	Max	Units
Turn-On Time	t_{ON}	$V_{COM}=V_{CC}$, $R_L=300\Omega$, $C_L=35pF$	5V	$+25^{\circ}C$		10		ns
			3.3V			14		
Turn-Off Time	t_{OFF}	$V_{COM}=V_{CC}$, $R_L=300\Omega$, $C_L=35pF$	5V	$+25^{\circ}C$		20		ns
			3.3V			22		
Break-Before-Make Time Delay	t_{BBM}	$V_{NO1}=V_{NC1}=V_{NO2}=V_{NC2}=3V$ $R_L=300\Omega, C_L=35pF$	5V	$+25^{\circ}C$		12		ns
			3.3V			20		
Off Isolation	O_{ISO}	$R_L=50\Omega$, Switch OFF	3.3V	$+25^{\circ}C$	f=10MHz		-52	dB
					f=1MHz		-73	
Crosstalk Isolation	X_{TALK}	$R_L=50\Omega$, Switch OFF, f=10MHz	3.3V	$+25^{\circ}C$		-89		dB
-3dB Bandwidth	BW	$R_L=50\Omega$, Switch ON	3.3V	$+25^{\circ}C$		350		MHz
Charge Injection	Q	$C_L=1nF$, $V_{GEN}=0V$, $R_{GEN}=0\Omega$	5V	$+25^{\circ}C$		6		pC
			3.3V			4		
NC,NO Off Capacitance	$C_{NC(OFF)}$, $C_{NO(OFF)}$	f=1MHz	3.3V	$+25^{\circ}C$		15		pF
NC,NO,COM On Capacitance	$C_{NC(ON)}$, $C_{NO(ON)}$, $C_{COM(ON)}$	f=1MHz	3.3V	$+25^{\circ}C$		8		pF

8 Typical Characteristics

$V_{CC}=1.65V$ or $5.5V$, FULL= $-40^{\circ}C$ to $+125^{\circ}C$. Typical values are at $T_A=+25^{\circ}C$ (unless otherwise noted)

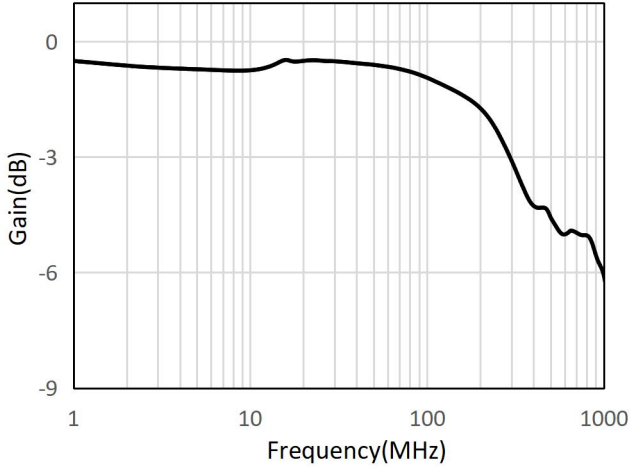

Fig.8-1. Bandwidth vs Frequency at 3.3V V_{CC}

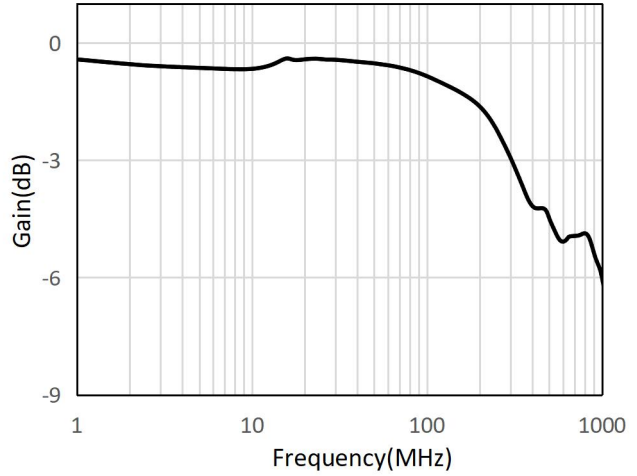

Fig.8-2. Bandwidth vs Frequency at 5V V_{CC}

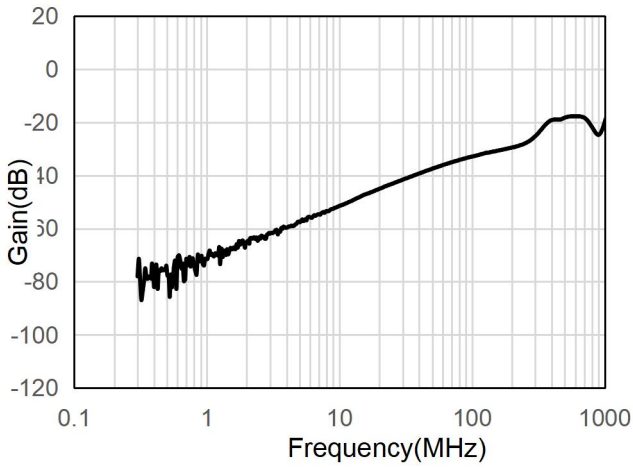

Fig.8-3. Off Isolation vs Frequency at 3.3V V_{CC}

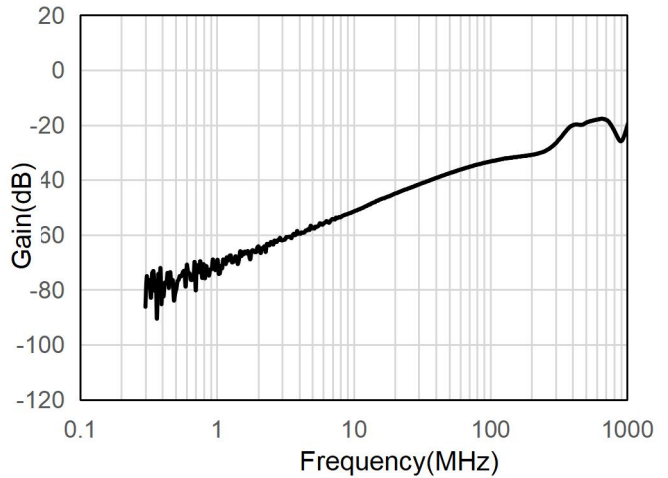
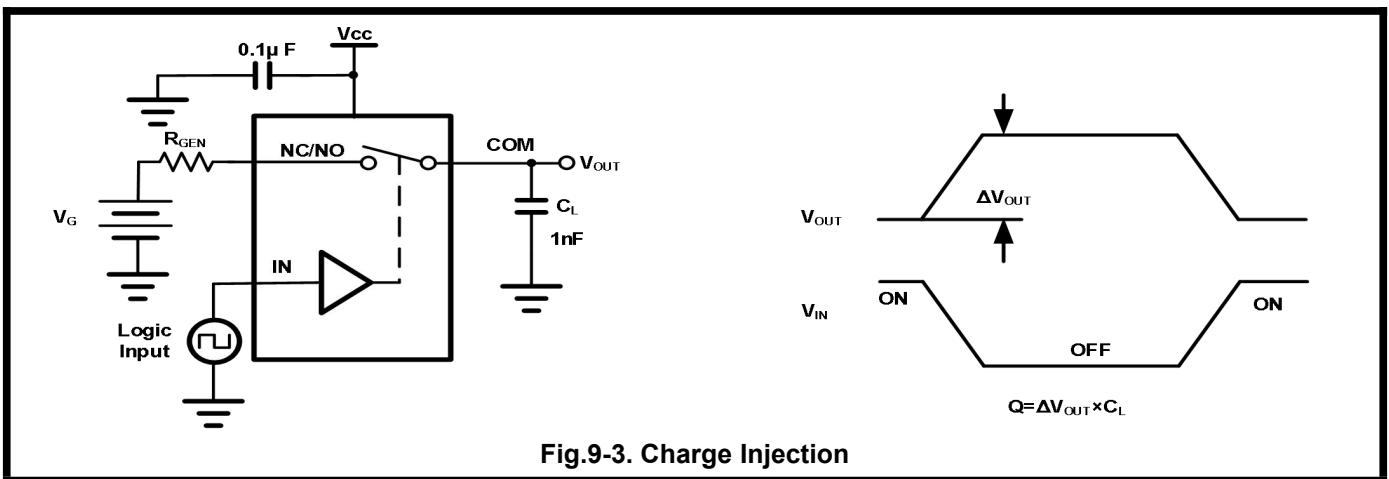
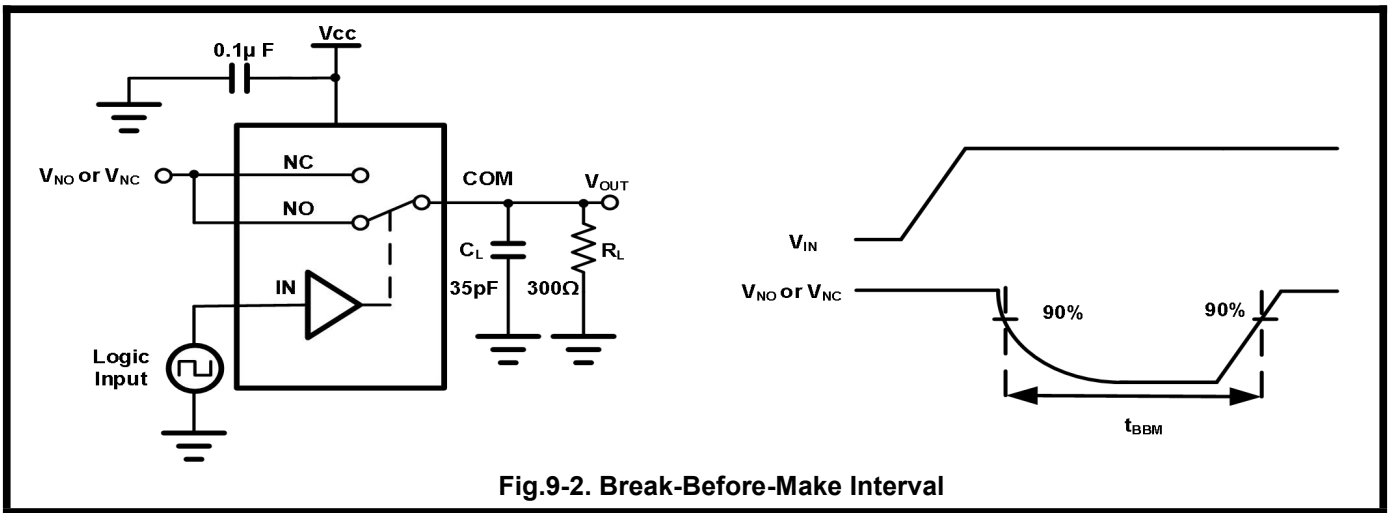
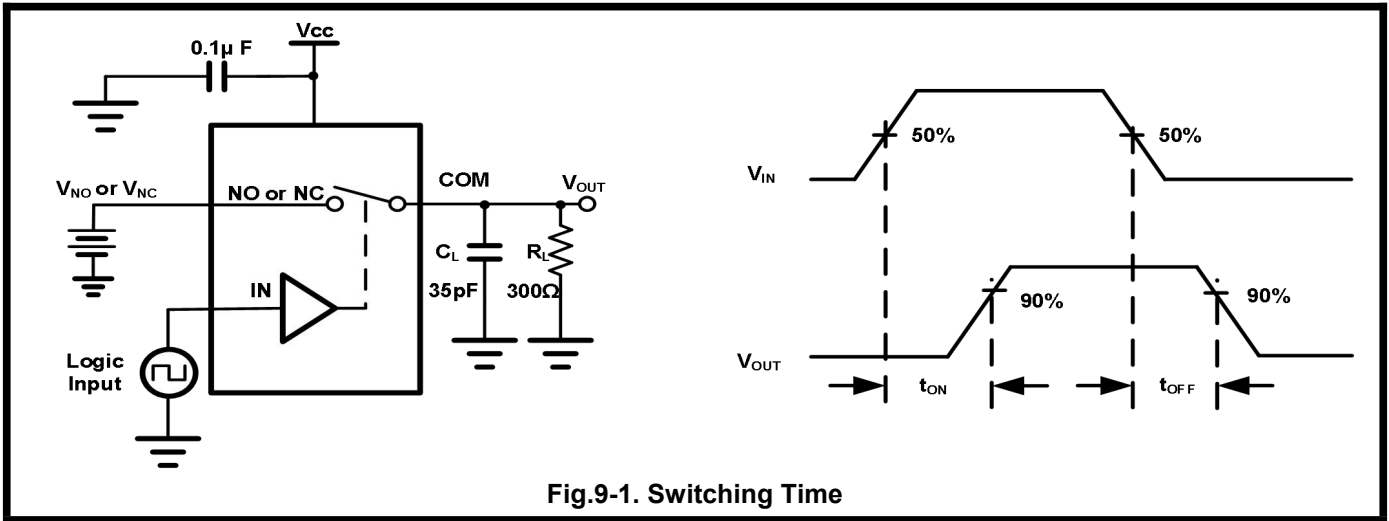
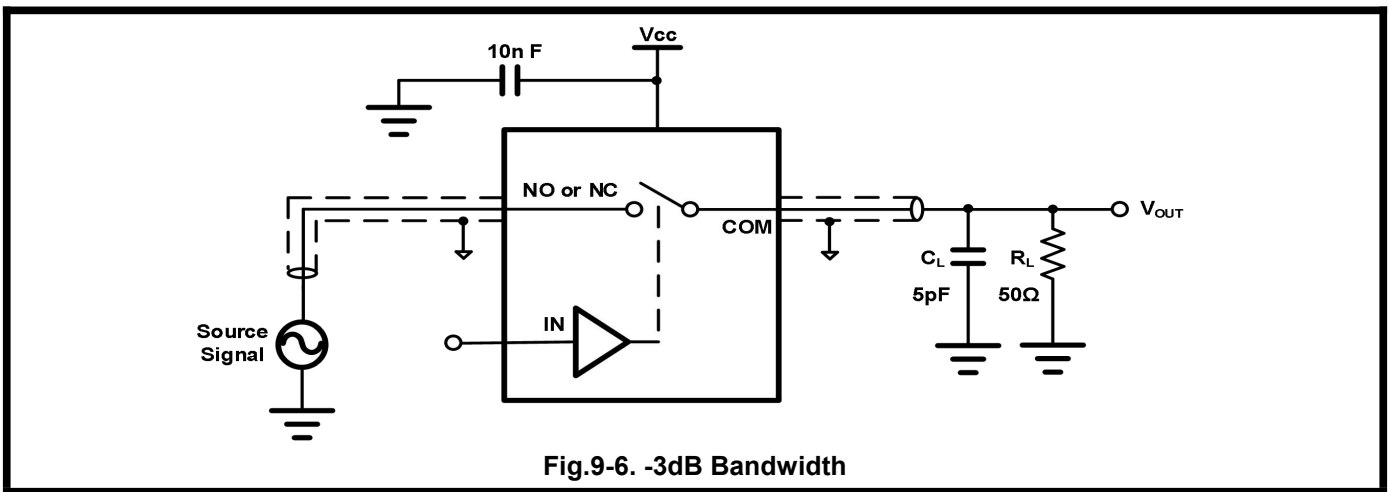
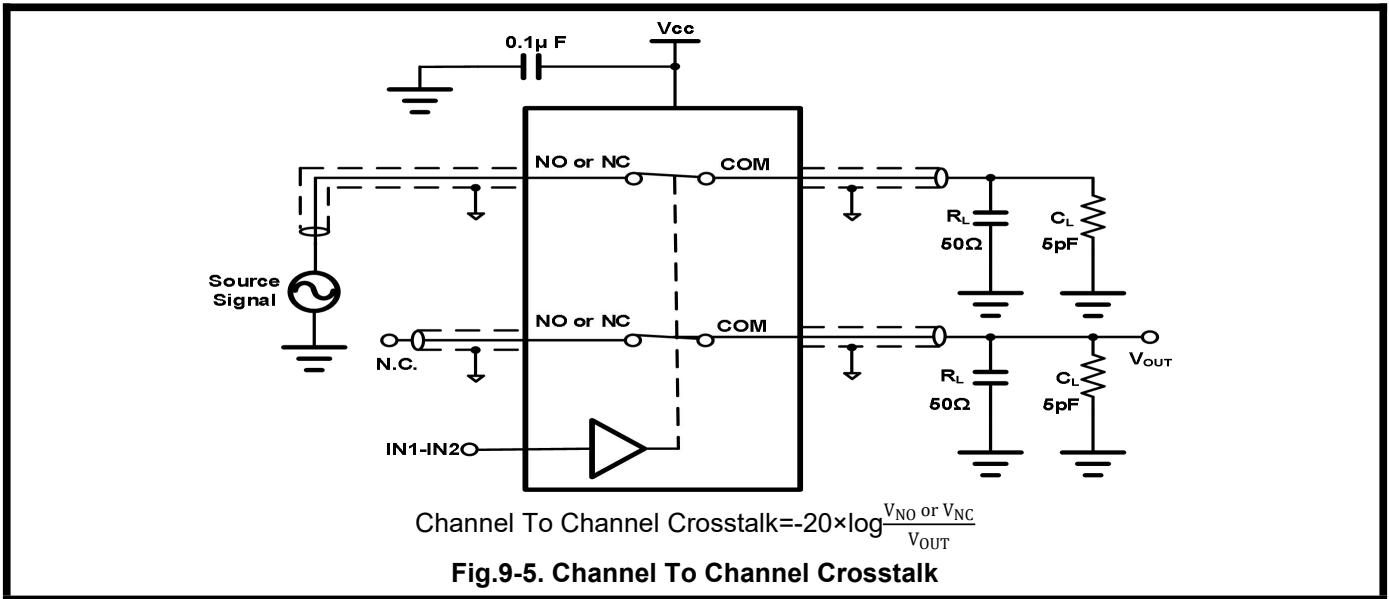
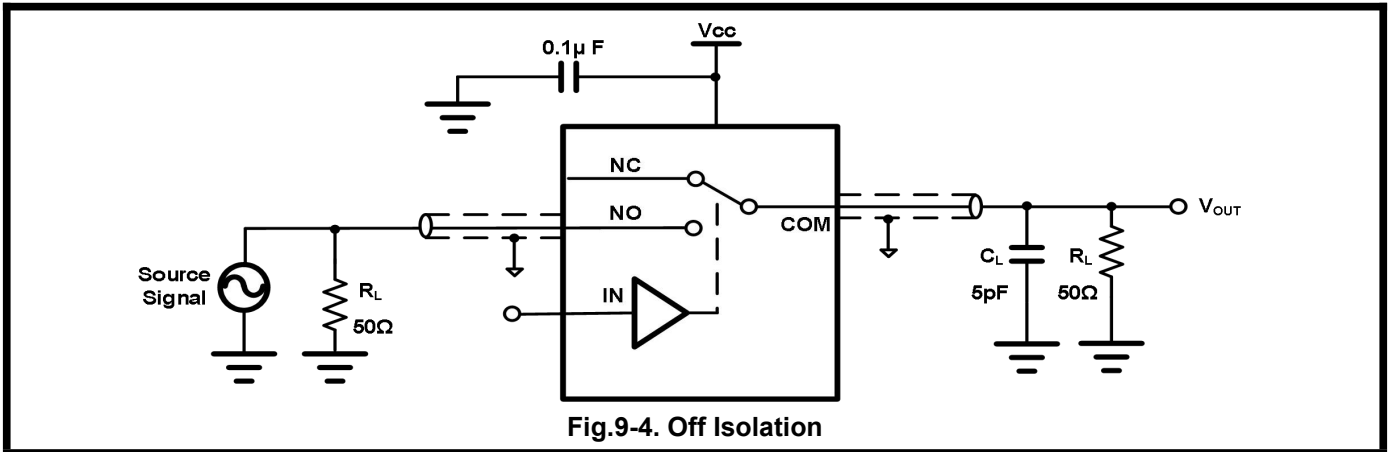

Fig.8-4. Off Isolation vs Frequency at 5V V_{CC}

9 Measurement Information



9 Measurement Information(Continued)



10 Package Outline Dimension

QFN3×3-16L

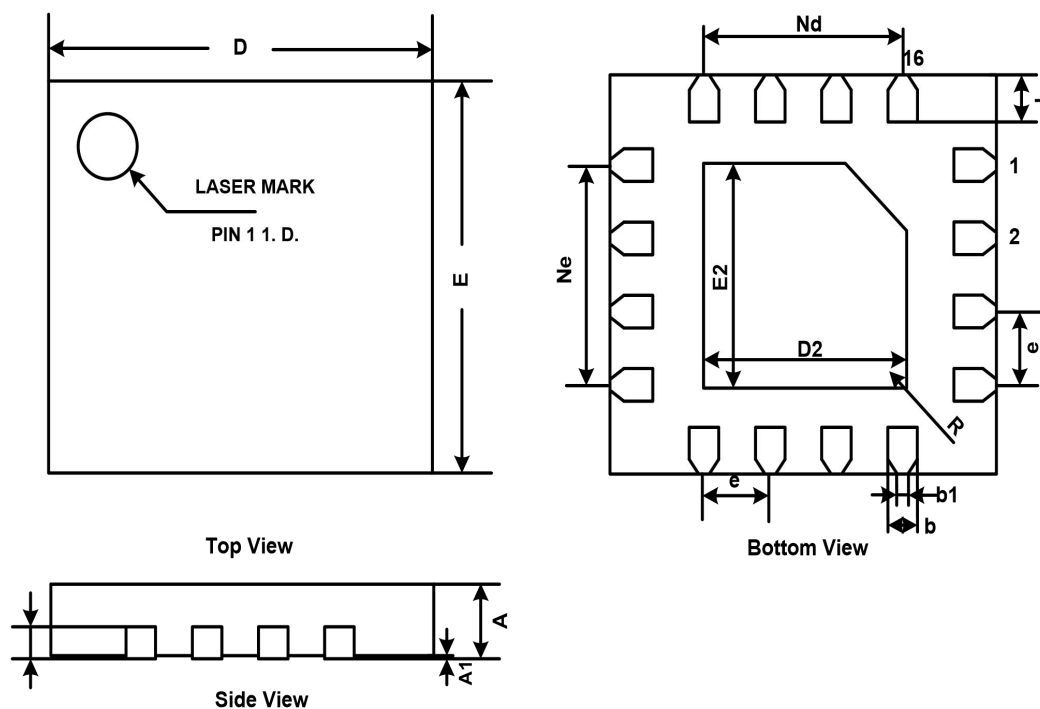

Symbol	Dimensions In Millimeters		Dimensions In Inches	
	Min	Max	Min	Min
A	0.700	0.800	0.028	0.032
A1	0.000	0.050	0.000	0.002
b	0.200	0.300	0.008	0.012
b1	0.230REF		0.009REF	
c	0.203REF		0.008REF	
D	2.900	3.100	0.116	0.124
D2	1.600	1.700	0.064	0.068
e	0.500BSC		0.020BSC	
Nd	1.500BSC		0.060BSC	
Ne	1.500BSC		0.060BSC	
E	2.900	3.100	0.116	0.124
E2	1.600	1.700	0.064	0.068
L	0.350	0.450	0.014	0.018
h	0.250	0.350	0.010	0.014
K	0.225	0.325	0.009	0.013
R	0.075REF		0.003REF	

10 Package Outline Dimension(Continued)

UTQFN1.8x2.6-16L

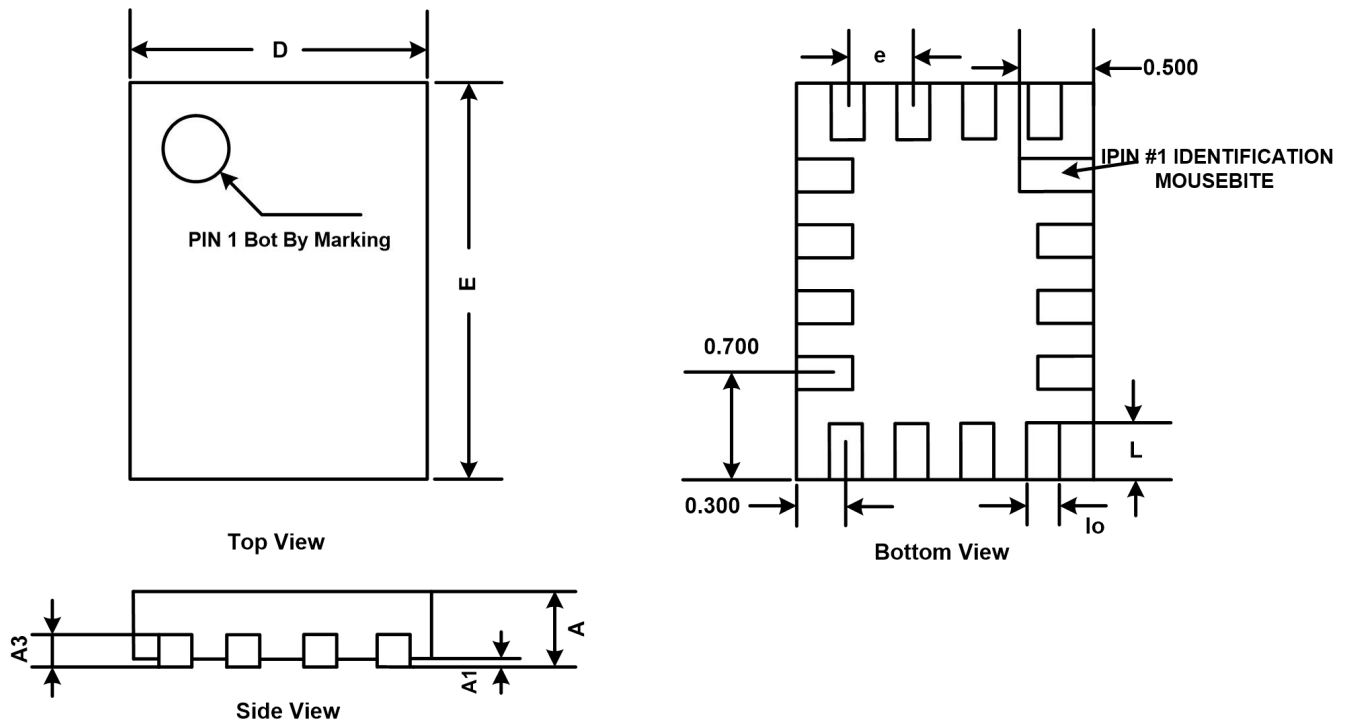

Symbol	Dimensions In Millimeters			Dimensions In Inches		
	Min	Nom	Max	Min	Nom	Max
A	>0.50	0.55	0.60	>0.19	0.21	0.23
A1	0.00	-	0.05	0.00	-	0.02
A3	0.15REF			0.06REF		
D	1.75	1.80	1.85	0.68	0.70	0.72
E	2.55	2.60	2.65	0.99	1.01	1.03
L	0.30	0.40	0.50	0.12	0.16	0.19
lo	0.15	0.20	0.25	0.06	0.08	0.10
e	0.40BSC			0.16BSC		

12 Tape and Reel Information

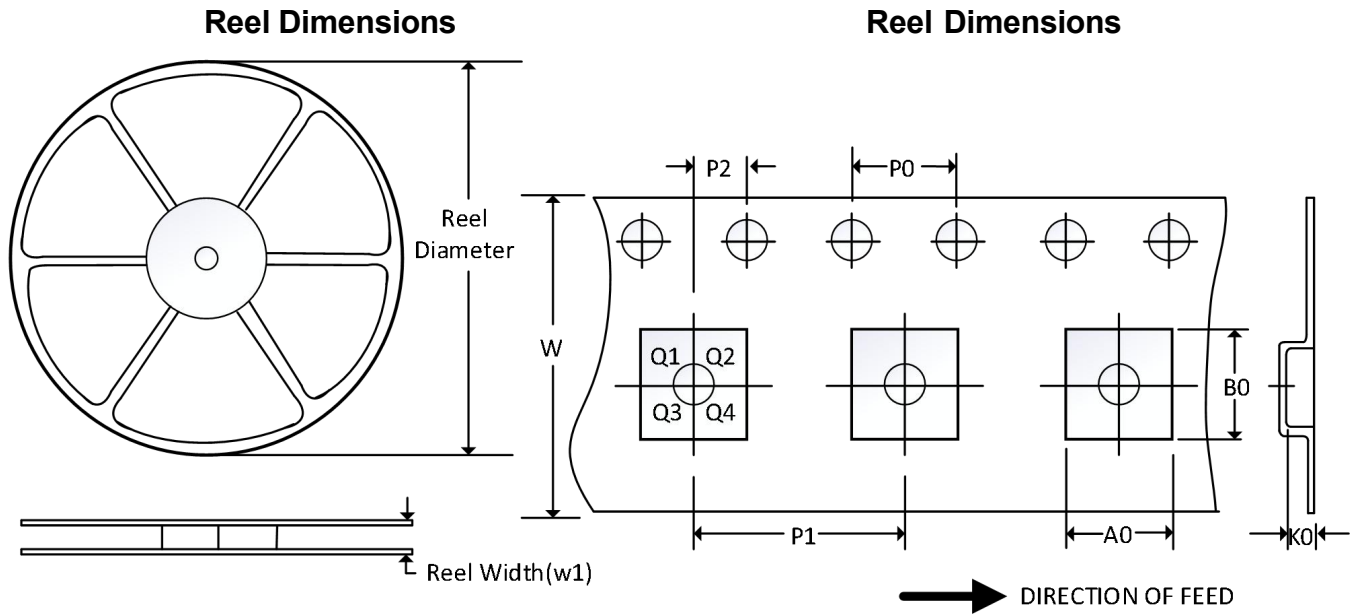

NOTE: The picture is only for reference. Please make the object as the standard.

Key Parameter List of Tape and Reel

Package Type	Reel Diameter	Reel Width (mm)	A0 (mm)	B0 (mm)	K0 (mm)	P0 (mm)	P1 (mm)	P2 (mm)	W (mm)	Pin1 Quadrant
QFN3×3-16L	178mm	12	3.23	3.23	1.05	4	4	2	12	Q1
UTQFN1.8×2.6-16L	178mm	9.04	2.1	2.9	0.75	4	4	2	8	Q1

NOTE:

1. All dimensions are nominal.
2. Plastic or metal protrusions of 0.15mm maximum per side are not included.